



CERTIFICATION



Approved. Sealed. Code Compliant.

Technical Evaluation Report

TER 1907-03

Big Timber® Screws for Use in Deck
Ledger Applications

**Western Builders Supply
DBA Big Timber**

Product:

Big Timber® CTX, BL, and GL Screws

Issue Date:

November 20, 2019

Revision Date:

November 20, 2019

Subject to Renewal:

October 1, 2020



**COMPANY
INFORMATION:**

Western Builders Supply
DBA Big Timber

53 N 15th St, Ste 1
Billings, MT 59101-2501

406-252-6309

sales@bigtimberfasteners.com

bigtimberfasteners.com

DIVISION: 06 00 00 - WOOD, PLASTICS AND COMPOSITES

SECTION: 06 05 23 - Wood, Plastic, and Composite Fastenings

SECTION: 06 11 00 - Wood Framing

SECTION: 06 15 00 - Wood Decking

1 PRODUCT EVALUATED¹

- 1.1 Big Timber® CTX, BL, and GL Screws

2 APPLICABLE CODES AND STANDARDS^{2,3}

2.1 Codes

- 2.1.1 *IBC—12, 15, 18: International Building Code®*
- 2.1.2 *IRC—12, 15, 18: International Residential Code®*

2.2 Standards and Referenced Documents

- 2.2.1 *AISI S904: Standard Test Methods for Determining the Tensile and Shear Strength of Screws*
- 2.2.2 *ANSI/AWC NDS: National Design Specification (NDS) for Wood Construction*
- 2.2.3 *ASTM A153: Standard Specification for Zinc Coating (Hot-Dip) on Iron and Steel Hardware*
- 2.2.4 *ASTM A510: Standard Specification for General Requirements for Wire Rods and Coarse Round Wire, Carbon Steel, and Alloy Steel*
- 2.2.5 *ASTM D1761: Standard Test Methods for Mechanical Fasteners in Wood*

¹ Building codes require data from valid research reports be obtained from approved sources. An approved agency, which is an approved source, is defined as "an established and recognized agency that is regularly engaged in...furnishing product certification where such agency has been approved..." Being approved, defined as "acceptable to the building official," is accomplished via accreditation using ISO/IEC 17065 evaluation procedures meeting code requirements of independence, adequate equipment, and experienced personnel. DrJ is an ISO/IEC 17065 ANSI-Accredited Product Certification Body - Accreditation #1131.

Through ANSI accreditation, DrJ certification can be used to obtain product approval in any country that is an IAF MLA Signatory and covered by an IAF MLA Evaluation per the Purpose of the MLA - "certified once, accepted everywhere." Manufacturers can go to jurisdictions in any IAF MLA Signatory Country and have their products readily approved by authorities having jurisdiction using DrJ's ANSI accreditation.

For more information on any of these topics or our mission, product evaluation policies, product approval process, and engineering law, see drjcertification.org.

² Unless otherwise noted, all references in this TER are from the 2018 version of the codes and the standards referenced therein (e.g., *ASCE 7*, *NDS*, *ASTM*). This material, design, or method of construction also complies with the 2000-2015 versions of the referenced codes and the standards referenced therein. As required by code, where this TER is not approved, the building official shall respond in writing stating the reasons this TER was not approved. For any variations in state and local codes, see Section 8.

³ All terms defined in the applicable building codes are italicized.

2.2.6 *ASTM F1575: Standard Test Method for Determining Bending Yield Moment of Nails*

3 PERFORMANCE EVALUATION

- 3.1 The Big Timber® screws listed in Section 1 were evaluated to determine:
 - 3.1.1 Use for attachment of deck ledgers to the building structure. This application includes attachments to SPF band joists⁴ and structural composite lumber (SCL) band joists.
 - 3.1.2 Lateral strength of ledger connections to wood framed walls in accordance with *ASTM D1761*. This application includes zero, one, or two layers of 5/8" gypsum between the ledger and the wall studs.
- 3.2 For conventionally framed buildings, the deck ledger is required to be attached to the band joist in accordance with *IBC Section 1604.8.3* or *IRC Section R507.9*⁵ as applicable.
 - 3.2.1 Where a band joist is not used, as in some truss installations, an engineered design is required. See Appendix A for additional code requirements for ledger attachments.
- 3.3 Any code compliance issues not specifically addressed in this section are outside the scope of this TER.
- 3.4 Any engineering evaluation conducted for this TER was performed on the dates provided in this TER and within DrJ's professional scope of work.

4 PRODUCT DESCRIPTION AND MATERIALS

4.1 The products evaluated in this TER are shown in Figure 1, Figure 2, and Figure 3.

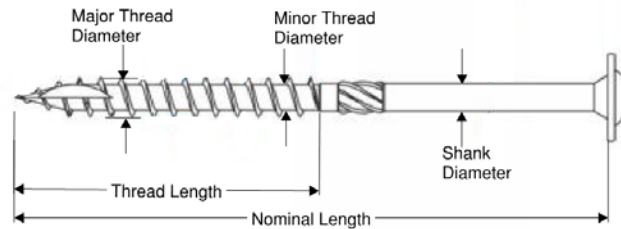

FIGURE 1. BIG TIMBER® CTX CONSTRUCTION LAG SCREW

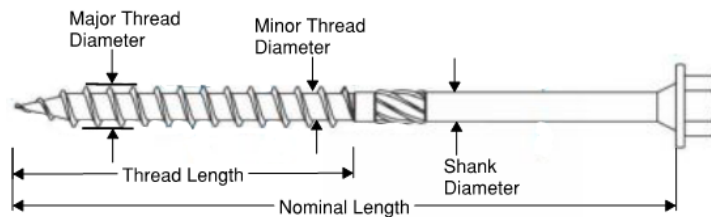

FIGURE 2. BL LOG, TIMBER & LANDSCAPING SCREW

⁴ The term "band joist" is used throughout this report. Other regionally used terms synonymous with band joist include rim board, band board, header board, and header joist.

⁵ 2009 IRC Section R502.2.2, 2015 IRC Section R507.2

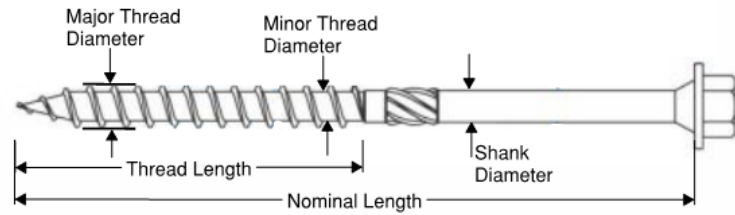

FIGURE 3. GL GRAY STRUCTURAL SCREW

4.2 The Big Timber® screws evaluated in this TER are set forth in Table 1.

TABLE 1. BIG TIMBER® FASTENER SPECIFICATIONS

| Fastener Name | Designation | Head (in) | | Nominal Length ¹ (in) | Thread Length ¹ (in) | Shank Diameter ² (in) | Thread Diameter (in) | | Specified Minimum Core Hardness ⁴ (HV 0.3) | Nominal Bending Yield, f_{yb} (psi) | Allowable Fastener Strength (lbf) | |
|---------------|-------------|-----------|------------|----------------------------------|---------------------------------|----------------------------------|----------------------|-------|---|---------------------------------------|-----------------------------------|--------------------|
| | | Diameter | Drive Type | | | | Minor | Major | | | Tensile | Shear ³ |
| CTX | 14 x 4 | 0.531 | Torx 25 | 4 | 2 | 0.168 | 0.146 | 0.242 | 355 | 141,300 | 930 | 725 |
| | 14 x 5 | | | 5 | 3 | | | | | | | |
| | 14 x 6 | | | 6 | 3 | | | | | | | |
| | 15 x 3½ | 0.620 | Torx 30 | 3½ | 2 | 0.202 | 0.179 | 0.275 | 355 | 151,600 | 1,475 | 1,020 |
| | 15 x 4 | | | 4 | 2 | | | | | | | |
| | 15 x 5 | | | 5 | 3 | | | | | | | |
| | 15 x 6 | | | | 6 | 3 | | | | | | |
| | 17 x 4 | 0.675 | Torx 40 | 4 | 2 | 0.226 | 0.210 | 0.295 | 355 | 170,500 | 1,850 | 1,240 |
| | 17 x 5 | | | 5 | 3 | | | | | | | |
| 17 x 6 | 5 | | | 3 | | | | | | | | |
| BL | 14 x 4 | 0.487 | Hex 5/16 | 4 | 2 | 0.189 | 0.171 | 0.258 | 300 | 177,700 | 1,085 | 725 |
| | 14 x 6 | | | 6 | 2 | | | | | | | |
| GL | 17 x 4 | 0.570 | Hex 5/16 | 4 | 2 | 0.224 | 0.211 | 0.297 | 355 | 172,600 | 1,990 | 1,240 |
| | 17 x 5 | | | 5 | 3 | | | | | | | |
| | 17 x 6 | | | 6 | 3 | | | | | | | |

SI: 1 in = 25.4 mm, 1 lb = 4.45 N, 1 psi = 0.00689 MPa

1. Fastener length is measured from the underside of the head to the tip. Thread length includes tapered tip (see Figure 1, Figure 2, and Figure 3).
2. Shank diameter based on manufactured thickness. Finished dimensions are larger, due to the proprietary coatings added.
3. Shear determined at smooth shank diameter.
4. Based on a 300 gram load using the Vickers indenter.

- 4.3 Big Timber® screws are manufactured using a standard cold-formed process followed by a heat-treating process.
- 4.4 CTX screws are coated with a proprietary coating, designated as Bronze Star, which exceeds the protections provided by hot-dipped galvanized coatings conforming to *ASTM A153*.
- 4.5 BL screws are coated with a proprietary coating, designated as Black Log, which exceeds the protections provided by hot-dipped galvanized coatings conforming to *ASTM A153*.

- 4.6 GL screws are coated with a proprietary coating, designated as Gray Log, which exceeds the protections provided by hot-dipped galvanized coatings conforming to *ASTM A153*.
- 4.7 Big Timber® screws are approved for use in chemically treated or untreated lumber where *ASTM A153, Class D* coatings are approved for use in accordance with *IBC Section 2304.10*⁶ and *IRC Section R317.3*.
 - 4.7.1 The proprietary coating has been tested and found to exceed the protection provided by code-approved hot-dipped galvanized coatings meeting *ASTM A153, Class D* (*IBC Section 2304.10.5*⁷ and *IRC Section R317.3*), allowing for its use in pressure treated wood.
 - 4.7.2 Big Timber® screws are approved for use in fire-retardant-treated lumber, provided the conditions set forth by the fire-retardant-treated lumber manufacturer are met, including appropriate strength reductions.

5 APPLICATIONS

5.1 General

- 5.1.1 Big Timber® CTX, BL, and GL screws are self-tapping fasteners used for attaching the deck ledger to the band joist of a building in accordance with *IBC Section 1604.8.3* and *IRC Section R507.9*⁸. See Section 6 for installation requirements.
- 5.1.2 Big Timber® CTX, BL, and GL screws can be used for attaching ledger boards to wall studs with zero, one, or two layers of GWB between the ledger and the wall studs.
- 5.1.3 Big Timber® CTX, BL, and GL screws are installed without lead holes, as prescribed in *NDS*.
- 5.1.4 Where the application exceeds the limitations set forth herein, design shall be permitted in accordance with accepted engineering procedures, experience, and technical judgment.
- 5.1.5 *Design*
 - 5.1.5.1 Design of Big Timber® CTX, BL, and GL screws are governed by the applicable code and the provisions for dowel-type fasteners in *NDS*.
 - 5.1.5.2 Unless otherwise noted, adjustment of the design stresses for duration of load shall be in accordance with the applicable code.

5.2 Design Values for Deck Ledger

- 5.2.1 Big Timber® CTX, BL, and GL screws are designed for attaching the deck ledger to the band joist of a building in accordance with *IBC Section 1604.8.3* and *IRC Section R507.9*.
 - 5.2.1.1 Where a band joist is not used, as in some truss installations, an engineered design is required. See Appendix A for additional code requirements for ledger attachments.
- 5.2.2 The *IRC* provides prescriptive fastener spacing for the attachment of a deck ledger to a rim joist with ½" diameter lag screws or through bolts as shown in *IRC Table R507.9.1.3(1)*⁹.
- 5.2.3 Table 2 and Table 3 provide the Big Timber® CTX, BL, and GL screw spacing required to provide performance at least equivalent to the lag screws found in *IRC Table R507.9.1.3(1)* in accordance with *IBC Section 104.11* and *Section 1604.8.3*, *IRC Section R104.11* and *Section R507.9*, and in accordance with generally accepted engineering practice.
 - 5.2.3.1 Table 2 and Table 3 provide screw spacing for materials found in *IRC Table R507.9*, as well as a wider range of materials commonly used for rim joists. Screw spacing values are provided for two loading conditions.

⁶ [2012 IBC Section 2304.9](#)

⁷ [2012 IBC Section 2304.9.5](#)

⁸ [2015 IRC Section R507.2](#)

⁹ [2015 IRC Section R507.2.1](#)

5.2.3.2 When installed in accordance with the spacing requirements of Table 2 and Table 3, Big Timber® BL & GL screws provide equivalent performance to IRC Table R507.9.

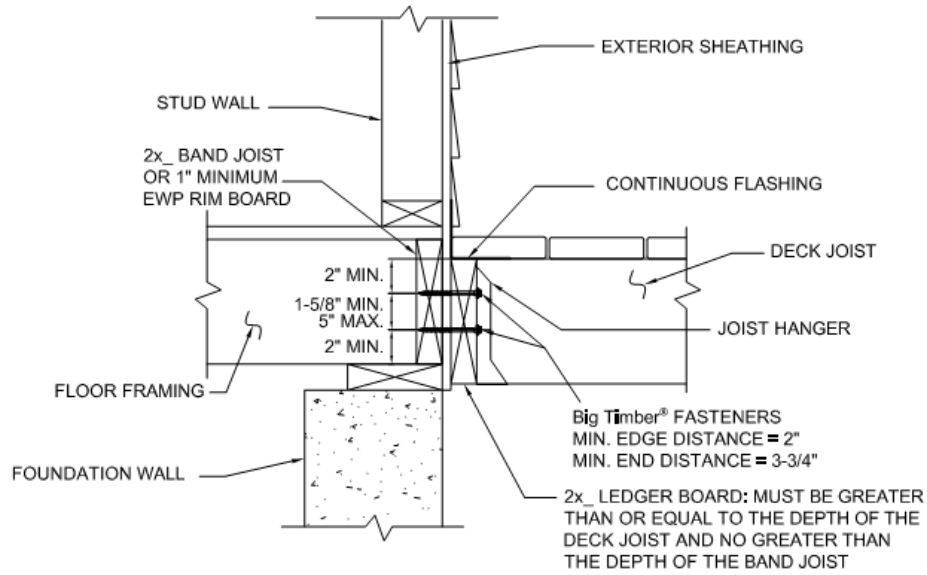

FIGURE 4. BIG TIMBER® DECK LEDGER CONNECTION

TABLE 2. CTX SCREW SPACING FOR ITEMS IN /IRC TABLE 507.9.1.3(1)⁹ AND OTHER MATERIALS AND LOADING CONDITIONS¹

| Loading Condition (LL + DL) (psf) | Fastener Designation ^{2,8} (in) | 2x Nominal Ledger Species ^{3,4,5} | Band Joist Material ^{6,7} | Maximum On-center Spacing of CTX Screws (in) | | | | | | | |
|-----------------------------------|--|--|------------------------------------|--|----------|-----------|-----------|-----------|-----------|-----------|---|
| | | | | Maximum Deck Joist Spans (ft) | | | | | | | |
| | | | | Up to 6' | Up to 8' | Up to 10' | Up to 12' | Up to 14' | Up to 16' | Up to 18' | |
| 40 + 10 | CTX 15 x 3.5 CTX 15 x 4 CTX 15 x 5 CTX 15 x 6 | HF/SPF | 2x Sawn Lumber | 6 | 5 | 4 | 3 | 2 | 2 | 2 | |
| | | | 1" Min SCL | 7 | 5 | 4 | 3 | 3 | 2 | 2 | |
| | | DF/SP | 2x Sawn Lumber | 7 | 5 | 4 | 3 | 3 | 2 | 2 | |
| | | | 1" Min SCL | 7 | 5 | 4 | 3 | 3 | 2 | 2 | |
| 60 + 10 | | CTX 15 x 3.5 CTX 15 x 4 CTX 15 x 5 CTX 15 x 6 | HF/SPF | 2x Sawn Lumber | 4 | 3 | 2 | 2 | 2 | 1 | 1 |
| | | | | 1" Min SCL | 5 | 3 | 3 | 2 | 2 | 1 | 1 |
| | | | DF/SP | 2x Sawn Lumber | 5 | 3 | 3 | 2 | 2 | 1 | 1 |
| | | | | 1" Min SCL | 5 | 4 | 3 | 2 | 2 | 2 | 1 |
| 40 + 10 | CTX 17 x 4 CTX 17 x 5 CTX 17 x 6 | | HF/SPF | 2x Sawn Lumber | 8 | 6 | 5 | 4 | 3 | 3 | 2 |
| | | | | 1" Min SCL | 8 | 6 | 5 | 4 | 3 | 3 | 2 |
| | | | DF/SP | 2x Sawn Lumber | 9 | 6 | 5 | 4 | 3 | 3 | 3 |
| | | | | 1" Min SCL | 9 | 7 | 5 | 4 | 4 | 3 | 3 |
| 60 + 10 | | CTX 17 x 4 CTX 17 x 5 CTX 17 x 6 | HF/SPF | 2x Sawn Lumber | 6 | 4 | 3 | 3 | 2 | 2 | 2 |
| | | | | 1" Min SCL | 6 | 4 | 3 | 3 | 2 | 2 | 2 |
| | | | DF/SP | 2x Sawn Lumber | 6 | 4 | 3 | 3 | 2 | 2 | 2 |
| | | | | 1" Min SCL | 6 | 5 | 4 | 3 | 2 | 2 | 2 |

 SI: 1 in = 25.4 mm, 1 psf = 0.0479 kN/m²

- Based on load duration of 1.0. Spacing may be adjusted by the applicable load duration as specified in *NDS*.
- Fasteners are required to have full thread penetration into the main member. Excess fastener length extending beyond the main member is not reflected in the table above.
- Solid sawn ledgers shall be HF/SPF or DFL/SP species (specific gravity of 0.42 and 0.50, respectively), designed by others.
- Minimum ledger board requirements: 1½" thickness and 7½" depth.
- Ledger materials assumed to be in the wet service condition.
- A maximum ½" structural sheathing may be installed between the ledger and band joist. Up to ½" thickness of stacked washers shall be permitted to substitute for up to ½" on allowable sheathing thickness where combined with wood structural panel or lumber sheathing.
- Minimum band joist requirements: SPF (specific gravity of 0.42) solid-sawn lumber 1½" thick and 7½" depth; SCL 1.0" thick and 7¼" depth.
- Fasteners shall be installed per Section 6 of this TER.
- 2015 *IRC* Table 507.2

TABLE 3. BL & GL SCREW SPACING FOR ITEMS IN /IRC TABLE 507.9.1.3(1)⁹ AND OTHER MATERIALS AND LOADING CONDITIONS¹

| Loading Condition (LL + DL) (psf) | Fastener Designation ^{2,8} (in) | 2x Nominal Ledger Species ^{3,4,5} | Band Joist Material ^{6,7} | Maximum On-center Spacing of BL & GL Screws (in) | | | | | | | |
|-----------------------------------|--|--|------------------------------------|--|----------|-----------|-----------|-----------|-----------|-----------|---|
| | | | | Maximum Deck Joist Spans (ft) | | | | | | | |
| | | | | Up to 6' | Up to 8' | Up to 10' | Up to 12' | Up to 14' | Up to 16' | Up to 18' | |
| 40 + 10 | BL 14 x 4 BL 14 x 6 | HF/SPF | 2x Sawn Lumber | 7 | 5 | 4 | 3 | 3 | 2 | 2 | |
| | | | 1" Min SCL | 7 | 5 | 4 | 3 | 3 | 2 | 2 | |
| | | DF/SP | 2x Sawn Lumber | 8 | 6 | 4 | 4 | 3 | 3 | 2 | |
| | | | 1" Min SCL | 8 | 6 | 4 | 4 | 3 | 3 | 2 | |
| 60 + 10 | | BL 14 x 4 BL 14 x 6 | HF/SPF | 2x Sawn Lumber | 5 | 4 | 3 | 2 | 2 | 2 | 1 |
| | | | | 1" Min SCL | 5 | 4 | 3 | 2 | 2 | 2 | 1 |
| | | | DF/SP | 2x Sawn Lumber | 5 | 4 | 3 | 2 | 2 | 2 | 1 |
| | | | | 1" Min SCL | 5 | 4 | 3 | 2 | 2 | 2 | 1 |
| 40 + 10 | GL 17 x 4 GL 17 x 5 GL 17 x 6 | | HF/SPF | 2x Sawn Lumber | 8 | 6 | 5 | 4 | 3 | 3 | 2 |
| | | | | 1" Min SCL | 8 | 6 | 5 | 4 | 3 | 3 | 2 |
| | | | DF/SP | 2x Sawn Lumber | 9 | 7 | 5 | 4 | 4 | 3 | 3 |
| | | | | 1" Min SCL | 9 | 7 | 5 | 4 | 4 | 3 | 3 |
| 60 + 10 | | GL 17 x 4 GL 17 x 5 GL 17 x 6 | HF/SPF | 2x Sawn Lumber | 6 | 4 | 3 | 3 | 2 | 2 | 2 |
| | | | | 1" Min SCL | 6 | 4 | 3 | 3 | 2 | 2 | 2 |
| | | | DF/SP | 2x Sawn Lumber | 6 | 5 | 4 | 3 | 2 | 2 | 2 |
| | | | | 1" Min SCL | 6 | 5 | 4 | 3 | 2 | 2 | 2 |

SI: 1 in = 25.4 mm, 1 psf = 0.0479 kN/m²

1. Based on load duration of 1.0. Spacing may be adjusted by the applicable load duration as specified in *NDS*.
2. Fasteners are required to have full thread penetration into the main member. Excess fastener length extending beyond the main member is not reflected in the table above.
3. Solid sawn ledgers shall be HF/SPF or DFL/SP species (specific gravity of 0.42 and 0.50, respectively), designed by others.
4. Minimum ledger board requirements: 1½" thickness and 7½' depth.
5. Ledger materials assumed to be in the wet service condition.
6. A maximum ½" structural sheathing may be installed between the ledger and band joist. Up to ½" thickness of stacked washers shall be permitted to substitute for up to ½" on allowable sheathing thickness where combined with wood structural panel or lumber sheathing.
7. Minimum band joist requirements: SPF (specific gravity of 0.42) solid-sawn lumber 1½" thick and 7½" depth; SCL 1.0" thick and 7¼" depth.
8. Fasteners shall be installed per Section 6 of this TER.
9. 2015 *IRC* Table 507.2

5.3 Reference Lateral Design Values for Ledger to Stud Attachment With or Without Gypsum Interlayer

- 5.3.1 Installation details for ledger to stud connections without gypsum wall board for 2x6, 2x8, and 2x10 ledgers are shown in Figure 5, Figure 6, and Figure 7, respectively.
- 5.3.2 Installation details for ledger to stud connections with a single layer of gypsum wall board for 2x6, 2x8, and 2x10 ledgers are shown in Figure 8, Figure 9, and Figure 10, respectively.
- 5.3.3 Installation details for ledger to stud connections with a double layer of gypsum wall board for 2x6, 2x8, and 2x10 ledgers are shown in Figure 11, Figure 12, and Figure 13, respectively.



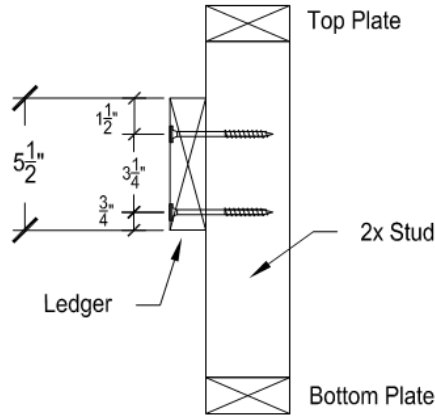

FIGURE 5. 2X6 LEDGER DIRECTLY ATTACHED TO STUD

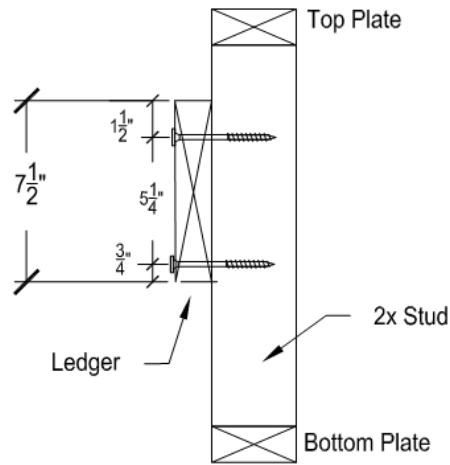

FIGURE 6. 2X8 LEDGER DIRECTLY ATTACHED TO STUD

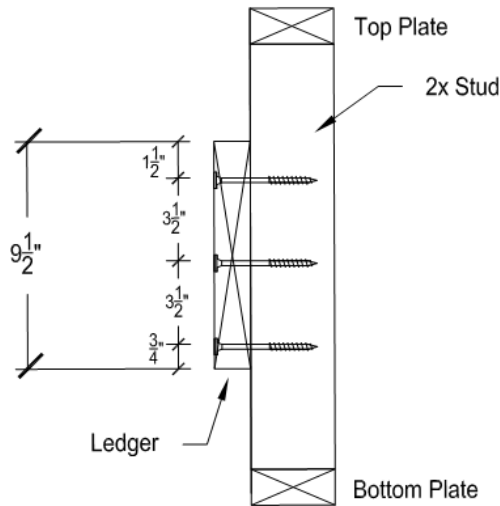

FIGURE 7. 2X10 LEDGER DIRECTLY ATTACHED TO STUD

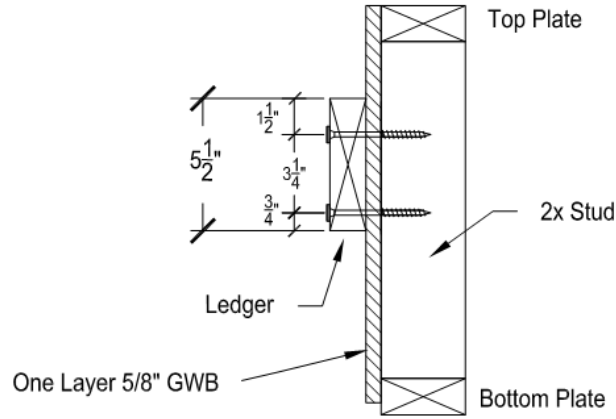

FIGURE 8. 2X6 LEDGER ATTACHED TO STUD THROUGH ONE LAYER OF GWB

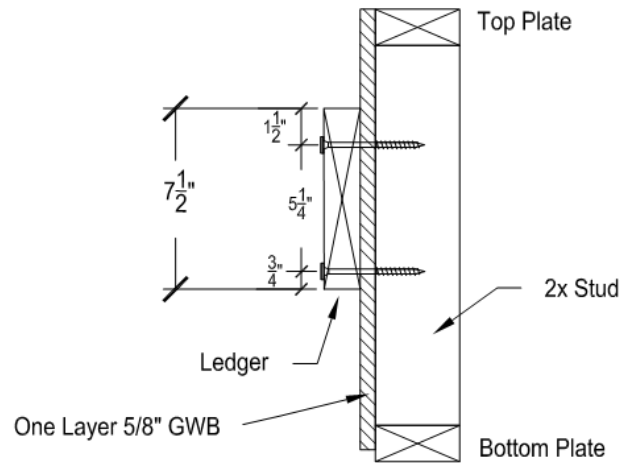

FIGURE 9. 2X8 LEDGER ATTACHED TO STUD THROUGH ONE LAYER OF GWB

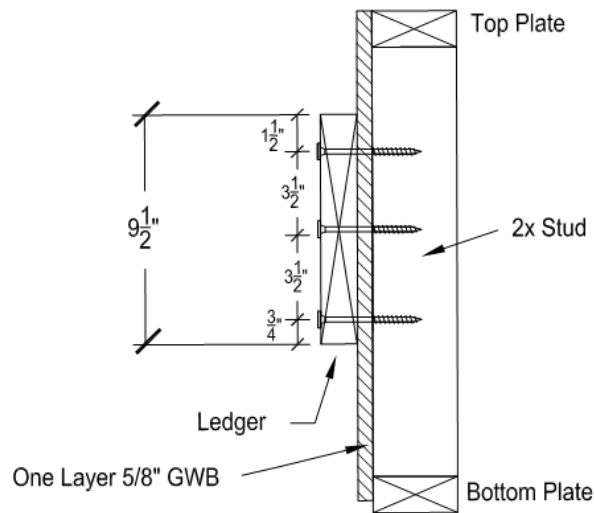

FIGURE 10. 2X10 LEDGER ATTACHED TO STUD THROUGH ONE LAYER OF GWB

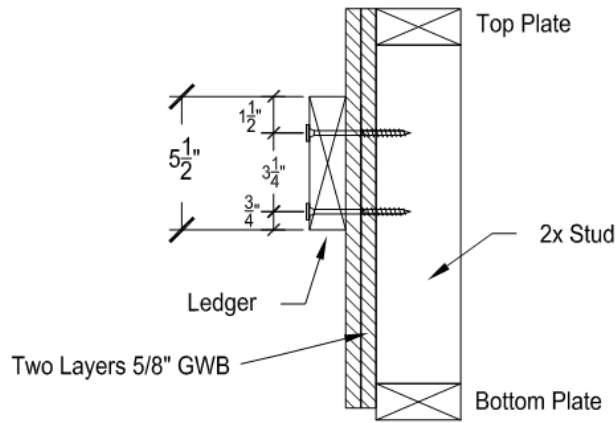

FIGURE 11. 2X6 LEDGER ATTACHED TO STUD THROUGH TWO LAYERS OF GWB

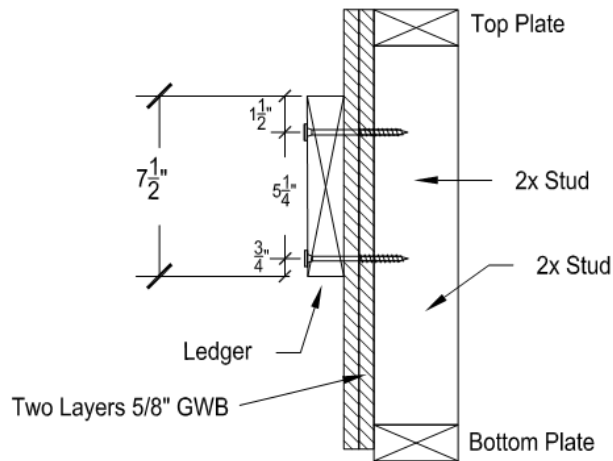

FIGURE 12. 2X8 LEDGER ATTACHED TO STUD THROUGH TWO LAYERS OF GWB

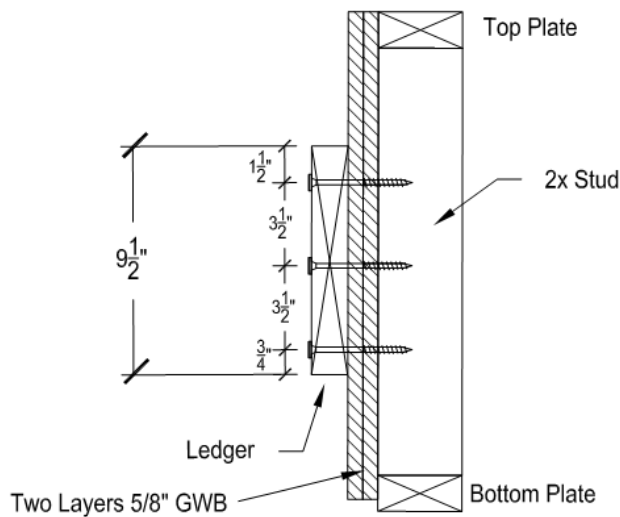

FIGURE 13. 2X10 LEDGER ATTACHED TO STUD THROUGH TWO LAYERS OF GWB

5.4 Reference lateral design values for the ledger to stud connections detailed in Figure 5 through Figure 13 are provided in Table 4 and Table 5. The values in Table 4 and Table 5 apply where the ledger is applied either directly over the studs or with up to two layers of 5/8" gypsum between the ledger and studs.

TABLE 4. CTX SCREW DESIGN VALUES FOR LEDGER TO STUD ATTACHMENT

| Fastener | Minimum Fastener Length ⁴ | Layers of GWB ⁵ | Ledger Size | Fasteners Per Stud ^{6,7} | Allowable Load per Stud Connection ^{1,2,3} (lb) | | |
|----------|--------------------------------------|----------------------------|-------------|-----------------------------------|--|-----|-----|
| | | | | | Lumber Species | | |
| | | | | | SPF | DF | SYP |
| CTX 14 | 4 | 0 | 2x6 | 2 | 245 | 285 | 315 |
| | | 1 | 2x8 | | 140 | 155 | 160 |
| | 5 | 2 | 2x10 | 3 | 135 | 140 | 145 |
| CTX 15 | 3½ | 0 | 2x6 | 2 | 340 | 430 | 470 |
| | | 1 | 2x8 | | 205 | 260 | 270 |
| | 5 | 2 | 2x10 | 3 | 245 | 255 | 260 |

SI: 1 in = 25.4 mm, 1 lb = 4.45 N

1. Allowable loads shall be limited to parallel-to-grain loaded solid sawn main members (minimum 2" nominal). Wood side members shall be loaded perpendicular to grain.
2. Allowable loads are shown at the wood load duration factor of $C_D = 1.00$. Loads may be increased for load duration as permitted by the building code up to a $C_D = 1.60$. All adjustment factors shall be applied per *NDS*. For in-service moisture content greater than 19%, use $C_M = 0.70$.
3. For LRFD values, the reference connection design values shall be adjusted in accordance with the *NDS* Section 11.3.
4. Required minimum fastener penetration is 6D into the main member, where D is the root minor diameter of the thread.
5. Gypsum board must be attached as required per the building code.
6. Fasteners shall be centered in the stud and spaced as shown in Figure 5 through Figure 13. Minimum end distances shall be per *NDS*.
7. Additional fasteners prohibited.

TABLE 5. BL & GL SCREW DESIGN VALUES FOR LEDGER TO STUD ATTACHMENT

| Fastener | Minimum Fastener Length ⁴ | Layers of GWB ⁵ | Ledger Size | Fasteners Per Stud ^{6,7} | Allowable Load per Stud Connection ^{1,2,3} (lb) | | |
|----------|--------------------------------------|----------------------------|-------------|-----------------------------------|--|-----|-----|
| | | | | | Lumber Species | | |
| | | | | | SPF | DF | SYP |
| BL 14 | 4 | 0 | 2x6 | 2 | 345 | 440 | 480 |
| | | 1 | 2x8 | | 245 | 270 | 280 |
| | 5 | 2 | 2x10 | 3 | 255 | 270 | 275 |
| GL 17 | 4 | 0 | 2x6 | 2 | 395 | 500 | 575 |
| | | 1 | 2x8 | | 275 | 360 | 390 |
| | 5 | 2 | 2x10 | 3 | 335 | 390 | 400 |

SI: 1 in = 25.4 mm, 1 lb = 4.45 N

1. Allowable loads shall be limited to parallel-to-grain loaded solid sawn main members (minimum 2" nominal). Wood side members shall be loaded perpendicular to grain.
2. Allowable loads are shown at the wood load duration factor of $C_D = 1.00$. Loads may be increased for load duration as permitted by the building code up to a $C_D = 1.60$. All adjustment factors shall be applied per *NDS*. For in-service moisture content greater than 19%, use $C_M = 0.70$.
3. For LRFD values, the reference connection design values shall be adjusted in accordance with the *NDS* Section 11.3.
4. Required minimum fastener penetration is $6D$ into the main member, where D is the root minor diameter of the thread.
5. Gypsum board must be attached as required per the building code.
6. Fasteners shall be centered in the stud and spaced as shown in Figure 5 through Figure 13. Minimum end distances shall be per *NDS*.
7. Additional fasteners prohibited.

6 INSTALLATION

- 6.1 Installation shall comply with the manufacturer’s installation instructions and this TER. In the event of a conflict between the manufacturer’s installation instructions and this TER, the more restrictive shall govern.
- 6.2 Lead holes are not required but may be used where lumber is prone to splitting.
- 6.3 Big Timber® screws shall be installed with the appropriate rotating powered driver. Do not overdrive.
- 6.4 Install Big Timber® screws such that the threads fully engage the band joist material and the fastener tip extends beyond the back face of the band joist material when fully seated against the installed ledger.
- 6.5 For deck ledger connections, stagger the Big Timber® screws from the top to the bottom along the length of the ledger while maintaining the required edge and end distances.
 - 6.5.1 Figure 4 provides a deck ledger installation detail, including minimum required spacing, end and edge distances.
- 6.6 For applications outside the scope of this TER, an engineered design is required.

7 TEST ENGINEERING SUBSTANTIATING DATA

- 7.1 Properties for Big Timber® CTX Construction Lag Screws are from DrJ TER 1907-01.
- 7.2 Properties for Big Timber® BL Log, Timber & Landscape Screws and GL Gray Structural Screws are from DrJ TER 1907-02.
- 7.3 *ANSI/AWC NDS: National Design Specification (NDS) for Wood Construction.*
- 7.4 Some information contained herein is the result of testing and/or data analysis by other sources which conform to *IBC Section 1703* and relevant [professional engineering law](#). DrJ relies on accurate data from these sources to perform engineering analysis. DrJ has reviewed and found the data provided by other professional sources to be credible.

- 7.5 Where appropriate, DrJ's analysis is based on design values that have been codified into law through codes and standards (e.g., *IBC*, *IRC*, *NDS*®, and *SDPWS*). This includes review of code provisions and any related test data that aids in comparative analysis or provides support for equivalency to an intended end-use application. Where the accuracy of design values provided herein is reliant upon the published properties of commodity materials (e.g., lumber, steel, and concrete), DrJ relies upon the grade mark, stamp, and/or design values provided by raw material suppliers to be accurate and conforming to the mechanical properties defined in the relevant material standard.

8 FINDINGS

- 8.1 When used and installed in accordance with this TER and the manufacturer's installation instructions, the product(s) listed in Section 1.1 are approved for the following:
- 8.1.1 Big Timber® screws provide an equivalent connection as that required by the *IBC* Section 1604.8.3 and *IRC* Section R507.9.
- 8.2 *IBC* Section 104.11 (*IRC* Section R104.11 and *IFC* Section 104.9 are similar) states:
- 104.11 Alternative materials, design and methods of construction and equipment.** The provisions of this code are not intended to prevent the installation of any material or to prohibit any design or method of construction not specifically prescribed by this code, provided that any such alternative has been *approved*. An alternative material, design or method of construction shall be *approved* where the *building official* finds that the proposed design is satisfactory and complies with the intent of the provisions of this code, and that the material, method or work offered is, for the purpose intended, not less than the equivalent of that prescribed in this code...Where the alternative material, design or method of construction is not *approved*, the *building official* shall respond in writing, stating the reasons the alternative was not *approved*.
- 8.3 This product has been evaluated in the context of the codes listed in Section 2 and is compliant with all known state and local building codes. Where there are known variations in state or local codes applicable to this evaluation, they are listed here.
- 8.3.1 No known variations

9 CONDITIONS OF USE

- 9.1 Big Timber® screws covered by this TER shall be installed in accordance with this report and the manufacturer's installation instruction.
- 9.2 Big Timber® screw spacing shall not exceed those listed in Table 4, Table 5, and Figure 4.
- 9.3 Use of fasteners in locations exposed to saltwater or saltwater spray is outside the scope of this evaluation report.
- 9.4 Where required by the *building official*, also known as the authority having jurisdiction (AHJ) in which the project is to be constructed, this TER and the installation instructions shall be submitted at the time of *permit* application.
- 9.5 Any generally accepted engineering calculations needed to show compliance with this TER shall be submitted to the AHJ for review and approval.
- 9.6 *Design loads* shall be determined in accordance with the building code adopted by the *jurisdiction* in which the project is to be constructed and/or by the Building Designer (e.g., *owner* or *registered design professional*).
- 9.7 At a minimum, this product shall be installed per Section 6 of this TER.
- 9.8 This product is manufactured under a third-party quality control program in accordance with *IBC* Section 104.4 and 110.4 and *IRC* Section R104.4 and R109.2.
- 9.9 The actual design, suitability, and use of this TER, for any particular building, is the responsibility of the *owner* or the owner's authorized agent. Therefore, the TER shall be reviewed for code compliance by the *building official* for acceptance.

- 9.10 The use of this TER is dependent on the manufacturer's in-plant QC, the ISO/IEC 17020 third-party quality assurance program and procedures, proper installation per the manufacturer's instructions, the building official's inspection, and any other code requirements that may apply to demonstrate and verify compliance with the applicable building code.

10 IDENTIFICATION

- 10.1 The product(s) listed in Section 1.1 are identified by a label on the board or packaging material bearing the manufacturer's name, product name, TER number, and other information to confirm code compliance.
- 10.2 Additional technical information can be found at bigtimberfasteners.com.

11 REVIEW SCHEDULE

- 11.1 This TER is subject to periodic review and revision. For the most recent version of this TER, visit drjcertification.org.
- 11.2 For information on the current status of this TER, contact [DrJ Certification](#).

APPENDIX A

Code Requirements for Ledger Attachments

For guidance on designing the connection of the deck ledger to trusses where a band joist is not used, see SBCA's Tech Note, *Attachment of Residential Deck Ledger to Metal Plate Connected Wood Truss Floor System.*

- 1) IRC Section R507.8¹⁰ contains the following code requirements (IBC Section 1604.8.3 is similar):
 - a) Where supported by attachment to an exterior wall, decks shall be positively anchored to the primary structure and designed for both vertical and lateral loads.
 - i) Attachment shall not be accomplished by the use of toenails or nails subject to withdrawal.
- 2) IRC Section R507.9.1 details how vertical loads shall be transferred to band joists with ledgers:
 - a) IRC Section R507.9.1.1
Deck ledgers shall be a minimum 2-inch by 8-inch (51 mm by 203 mm) nominal, pressure-preservative-treated Southern pine, incised pressure-preservative-treated hem-fir, or approved, naturally durable, No. 2 grade or better lumber...
 - b) IRC Section R507.9.1.2
Band joists supporting a ledger shall be a minimum 2-inch-nominal (51 mm), spruce-pine-fir or better lumber or a minimum 1-inch by 9½-inch (25 mm x 241 mm) dimensional, Douglas fir or better, laminated veneer lumber. Band joists shall bear fully on the primary structure capable of supporting all required loads.
 - c) IRC Section R507.9.1.3¹¹
Fasteners used in deck ledger connections in accordance with Table R507.9.1.3(1) shall be hot-dipped galvanized or stainless steel and shall be installed in accordance with Table R507.9.1.3(2) and Figures R507.9.1.3(1) and R507.9.1.3(2).

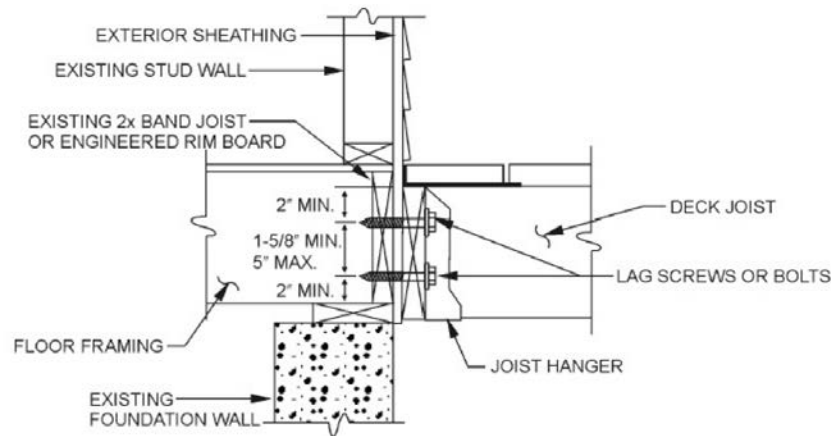

For SI: 1 inch = 25.4 mm.

FIGURE 14. PLACEMENT OF LAG SCREWS AND BOLTS IN BAND JOISTS, IRC FIGURE R507.9.1.3(2)

- d) Tables R507.9.1.3(1) and R507.9.1.3(2)¹² cover the placement of lag screws or bolts in deck ledgers:
The tip of the lag screw shall fully extend beyond the inside face of the band joist.

¹⁰ 2012 IRC Section R507.1, 2015 IRC Section R507.1

¹¹ 2012 IRC Section R507.2, 2015 IRC Section R507.2

¹² 2012 IRC Section R507.2.1, 2015 IRC Section R507.2.1

Lag screws or bolts shall be staggered from the top to the bottom along the horizontal run of the deck ledger in accordance with Figure R507.9.1.3(1).

The minimum distance from bottom row of lag screws or bolts to the top edge of the ledger shall be in accordance with Figure R507.9.1.3(1).

| CONNECTION DETAILS | JOIST SPAN | | | | | | |
|---|--------------------------------|------------|-------------|--------------|--------------|--------------|--------------|
| | 6' and less | 6'1" to 8' | 8'1" to 10' | 10'1" to 12' | 12'1" to 14' | 14'1" to 16' | 16'1" to 18' |
| | On-center spacing of fasteners | | | | | | |
| 1/2-inch diameter lag screw with 1/2-inch maximum sheathing ^{c, d} | 30 | 23 | 18 | 15 | 13 | 11 | 10 |
| 1/2-inch diameter bolt with 1/2-inch maximum sheathing ^d | 36 | 36 | 34 | 29 | 24 | 21 | 19 |
| 1/2-inch diameter bolt with 1-inch maximum sheathing ^e | 36 | 36 | 29 | 24 | 21 | 18 | 16 |

For SI: 1 inch = 25.4 mm, 1 foot = 304.8 mm, 1 pound per square foot = 0.0479 kPa.

- a. Ledgers shall be flashed in accordance with Section R703.4 to prevent water from contacting the house band joist.
- b. Snow load shall not be assumed to act concurrently with live load.
- c. The tip of the lag screw shall fully extend beyond the inside face of the band joist.
- d. Sheathing shall be wood structural panel or solid sawn lumber.
- e. Sheathing shall be permitted to be wood structural panel, gypsum board, fiberboard, lumber or foam sheathing. Up to 1/2-inch thickness of stacked washers shall be permitted to substitute for up to 1/2 inch of allowable sheathing thickness where combined with wood structural panel or lumber sheathing.

FIGURE 15. DECK LEDGER CONNECTION TO BAND JOIST^{A,B}, TABLE R507.9.1.3(1)
(DECK LIVE LOAD = 40 PSF, DECK DEAD LOAD = 10 PSF, SNOW LOAD ≤40 PSF)

| MINIMUM END AND EDGE DISTANCES AND SPACING BETWEEN ROWS | | | | |
|---|-----------------------|-------------|-----------------------|---------------------------|
| | TOP EDGE | BOTTOM EDGE | ENDS | ROW SPACING |
| Ledger ^a | 2 inches ^d | 3/4 inch | 2 inches ^b | 1 5/8 inches ^b |
| Band Joist ^c | 3/4 inch | 2 inches | 2 inches ^b | 1 5/8 inches ^b |

For SI: 1 inch = 25.4 mm.

- a. Lag screws or bolts shall be staggered from the top to the bottom along the horizontal run of the deck ledger in accordance with Figure R507.9.1.3(1).
- b. Maximum 5 inches.
- c. For engineered rim joists, the manufacturer's recommendations shall govern.
- d. The minimum distance from bottom row of lag screws or bolts to the top edge of the ledger shall be in accordance with Figure R507.9.1.3(1).

FIGURE 16. PLACEMENT OF LAG SCREWS AND BOLTS IN DECK LEDGERS AND BAND JOISTS, TABLE R507.9.1.3(2)

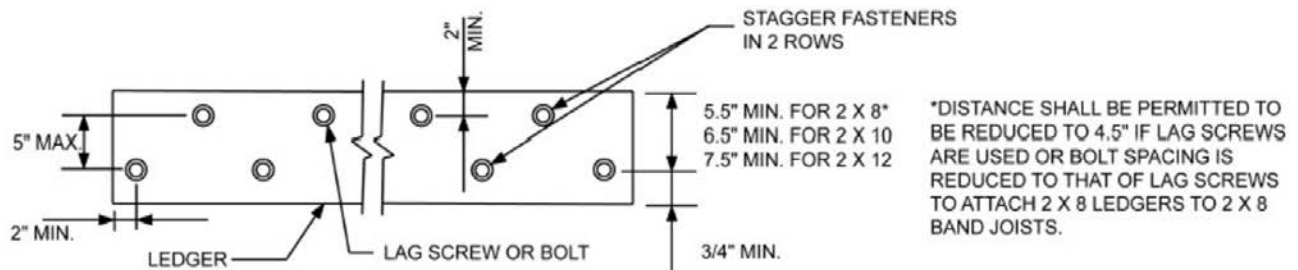

For SI: 1 inch = 25.4 mm.

FIGURE 17. PLACEMENT OF LAG SCREWS AND BOLTS IN LEDGERS, FIGURE R507.9.1.3(1)